

## DUET 4W

Thanks for choosing our DUET4W products.  
We strongly recommend that you read this manual carefully before installation.

### Product Specifications

PRODUCT CODE	MAX POWER CONSUMPTION ( WHEN CHARGING )	IP RATING	INPUT RATING	OPERATING TEMPERATURE	ELECTRICAL CLASSIFICATION	EM TIME
DUET4W	4.5W	IP20	220 – 240Va.c. 50/60Hz	0-45°	Class II	>1.5hr

The Haneco DUET Surface Mount Non-Maintained Emergency LED Floodlight can be installed on plaster walls or solid block surfaces. The DUET4W comes with a 1.2m flex and plug for easy power connection.

### Testings

The Haneco DUET4W must be allowed to charge the battery for 16 hours when the fitting is connected to un-switched active prior to operation. The product shall be tested in accordance to the instructions below:

#### 1. Operational test

- Press and hold test button or switch off power, check that both lamps are on.
- Release the test button or switch on power, check that both lamps are off.

#### 2. Duration test

- Press test button once and check that both lamps remain on for at least 2 hours after the first installation (and at least 1.5 hours for the following tests). All test results must be recorded in a service logbook that should be kept on-site at all time. Should the unit fail the test, remedial action must be taken.

For any malfunction such as indicator failure, lamp not illuminated in EM mode or not illuminated for more than 1.5 hours, please check:

- Main power is connected, and turned on.
- Battery is connected.
- Battery, test switch and lamp head for any damage.
- Battery has been allowed to charge for at least 16 hours.

### Attention!

Power circuits may not be powered on most building sites in Australia during construction. Fittings on these circuits will have their batteries or power storage units discharged. The LiFePO4 battery of Haneco DUET is designed to perform an excellent long-life in a controlled AS/NZS 60598.2.22 testing environment. Excessive battery discharging would reduce this performance and cause battery failures. Battery warranty claims as a result of such abuse are specifically excluded from Haneco warranty terms.

## DUET

### Installation Instructions

- 1** Switch-off main power.

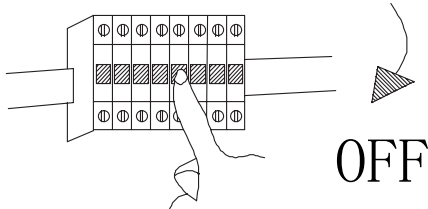

- 2** Fix four screws on the installation surface.

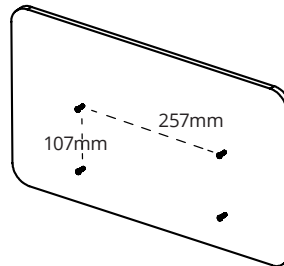

- 3** Put product on the mounting surface, adjust until fitting can sit stable on the mounting screws.

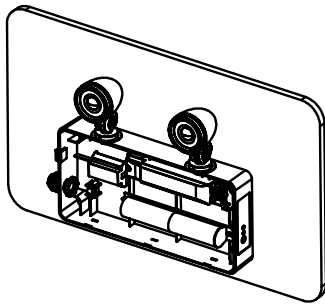

- 4** Connect the fitting to main by either of the following two ways:  
 a) Connect the flex and plug with a surface socket or nearby power outlet directly.  
 b) Remove flex and plug, wire to main as illustrated below.

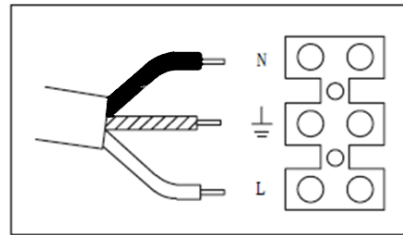

- 5** Put the cover back on.

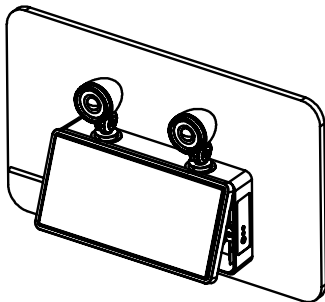

- 6** Finish the installation and turn power back on.

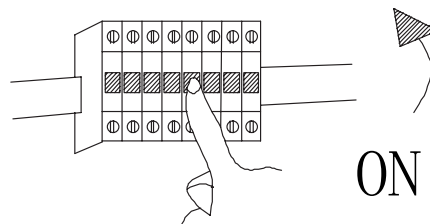

#### WARNING

The luminaire must be installed by a professional electrician.  
 Always switch the power off when wiring the luminaire.  
 Ensure input voltage conforms to the voltage range of product.  
 Ensure wires are securely connected.  
 Before switching on, ensure that all the wiring is correct.  
 Warranty is void if product is not installed according to the instructions.

Product Code: **DUET4W**