

**EDGY™ Series**

# Unison™ Powerpoint

EG2PPH

**KASTA**

**UNISON™**  
RANGE



## Double horizontal powerpoint

### FEATURES

- Slim (7.8mm plate depth), contemporary design
- UV stabilised to avoid discolouring
- Fits standard first fix mounting accessories (e.g. C-clips, nail brackets, wall boxes)
- Flush mounting centres (not recessed) for quicker installation
- Deep guided cable terminals allow for fast fitment of cables
- Multiple mounting facilities at both 84mm and 100mm, along with corner fixing points
- Colour coded terminals for ease of identification
- Suitable for loads that use plugs with two or three flat pins
- 5 year warranty

### CONNECTION

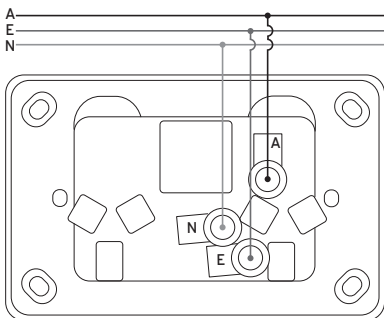

### SPECIFICATIONS

Power Supply	220-240V a.c.
Operating Ambient Temperature	-20 to 40°C
IP Rating	IP20
Current Rating	10A
Plate Depth	7.8mm
Terminal Size	16mm <sup>2</sup> (accommodates 4x2.5mm <sup>2</sup> cables)
Terminal Screw Type	Combination Flat/Philips head
Mounting Points	84mm / 100mm and Corners
Mounting Screw Type	Combination Flat/Philips head
Plate Colour (Finish)	White (Gloss) / Black (Matte) / Grey (Matte)
Housing Material	Acrylic / Polycarbonate (PC)
Standards Complied	AS/NZS 3112, AS/NZS 3100

### ORDERING CODE

**EG2PPH-WH**

(plate finish)

WH - White  
MBK - Matte Black  
GY - Grey

### COLOURS

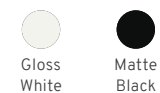

### DIMENSIONS

