

# HESPERUS™ Series

## Multivue™ Remote Switch

H5MSMB



### 5-button remote switch interface with LCD display for multiple page view

#### FEATURES

- 5-button control with multiple LCD screen pages allows users to dynamically manage and monitor groups, scenes and individual devices (up to 20 devices/scenes or rooms)
- Clear digital icons for easy identification of device to be controlled
- Proximity sensor activates the device for use
- Ambient temperature indicator (in-built sensor)
- Language options: English / Mandarin (simplified)
- UV stabilised to avoid discolouring
- Soft push buttons (with audio feedback) can be programmed to perform a variety of in-room and whole home control functions, for remote control of all KASTA devices
- Flexibility to program and re-program during and after commissioning
- Short press for ON/OFF control, long press for dimming or fan speed control
- Reliable Bluetooth® mesh network connectivity to all your KASTA devices
- Wi-Fi connectivity to enable device to be updated with the latest software features
- Fits standard first fix mounting accessories (e.g. C-clips, nail brackets, wall boxes)
- Flush mounting centres (not recessed) for quicker installation
- Backed off terminal screws and deep tunnels allow fast fitment of cables
- Insulated screw caps hinged to the grid plate to provide IP2X rating on mounting screws
- iOS and Android app setup and control
- 3 year warranty

#### SPECIFICATIONS

Power Supply	220-240V a.c. 50Hz
Operating Ambient Temperature	-20 to 40°C
Wi-Fi Connectivity	Wi-Fi 802.11 g/b/n, 2.4Ghz
IP Rating	IP20
Plate Depth	13mm
Terminal Size	16mm <sup>2</sup> (accommodates 4x2.5mm <sup>2</sup> cables)
Terminal Screw Type	Flat Terminal Screw
Mounting Points	84mm / 100mm and Corners
Mounting Screw Type	Combination Flat / Philips Head Screws
Frame Colour (Finish)	Black (Matte)
Plate Colour (Finish)	White / Black (Transparent)
Housing Material	Acrylic / Polycarbonate (PC)
LED Indicators	Blue, White, Green, OFF (selectable through the KASTA app)
Standards Complied	AS/NZS 62368.1, AS/NZS 4268, AS/NZS CISPR 32

#### DIMENSIONS

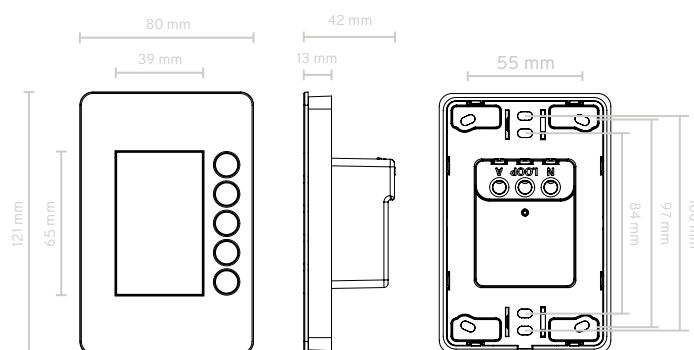

#### ORDERING CODE

**H5MSMB-WH**  
(plate finish)

WH - White  
BK - Black

#### COLOURS



#### CONNECTION

