

# Dimmer Mechanism

KASTA-DM300BH-W



Smart push button dimmer mechanism (phase cut trailing edge) that clips into standard wall plate

## FEATURES

- Mains powered phase cut trailing edge (TE) dimmer
- 2-wire connection for easy installation
- Slim design allows installation up to 6-gang onto a standard wall plate
- Reliable Bluetooth® mesh network connectivity to all your KASTA devices
- 8-way multiway control
- Short press for ON/OFF control
- Long press for dimming control
- Over-current protection
- Supports core KASTA functionality - control devices, groups, scenes, timers and scheduling
- Suits most Australian wall plates
- Supplied with White button caps (2 x styles)
- iOS and Android app setup and control
- 3 year warranty

## CONNECTION

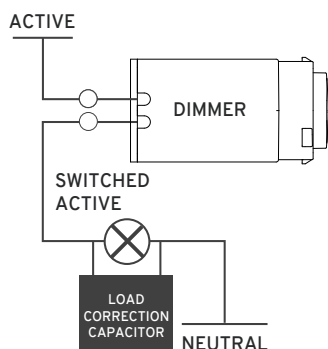

## SPECIFICATIONS

Power Supply	220-240V a.c. 50Hz
Operating Ambient Temperature	-20 to 40°C
IP Rating	IP20
Thermal Derating	25 to 40°C (300W-100W)
Physical Connection Type	Fly leads
Wiring Connections	Active & Load
LED Load Wattage	3W* - 300W**
Dimming Method	Phase Cut Trailing Edge
Dimming Range	2-100%
Multi-gang Derating	2-270W, 3-240W, 4-200W, 5-150W, 6-100W @ 25°C
Housing Material	Polycarbonate (PC)
LED Indicators	Blue
Standards Complied	AS/NZS 60669.2.1, AS/NZS 60669.1, AS/NZS CISPR 15, AS/NZS 4268

\*May require load correct capacitor if less than 15W (supplied in box).

\*\*Maximum load is based on Haneco Dimmable LED drivers. Other LED loads may not be compatible. Contact the manufacturer for compatibility advice.

## DIMENSIONS

