

MATRIX G3 Power Switchable

Thanks for choosing our MATRIX G3 products.
We strongly recommend that you read this manual carefully before installation.

Product Specifications

Other wattages available on driverless models

PRODUCT CODE	SAP CODE	FEATURE	POWER	CCT	LUMEN	NET WEIGHT
MATRIX18W0303	2001956	Tritone	18W	4000K 4500K 5000K	2050lm	1.10kg
MATRIX18W0306	2001957					
MATRIX0312-PS	2002072	Tritone Power Switchable	25W 28W 32W 36W		3000lm 3300lm 3700lm 4100lm	1.85kg
MATRIX0606-PS	2002073					
MATRIX25W0312	2001958	Tritone	25W		3000lm	1.85kg
MATRIX25W0606	2002071					
MATRIX48W0612	2001962		48W		5400lm	3.90kg

Installation Instructions

1. Remove the ceiling plaster panel.
2. Connect the LED panel to the driver and plug it into the socket.
3. Install the fitting into the required location and test for safety and operation.

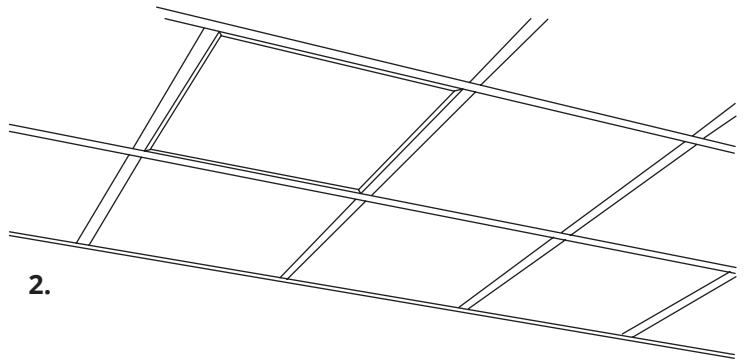
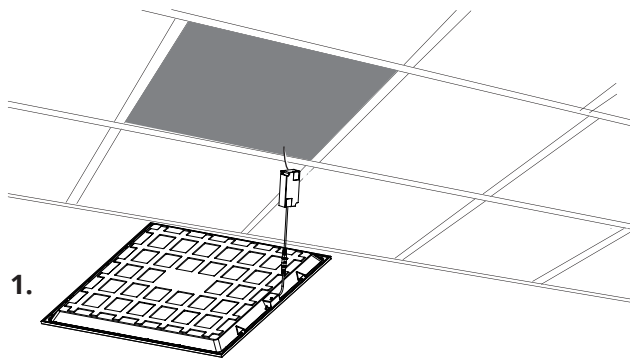

WARNING

The luminaire must be installed by professional electrician.
Switch power off when wiring the luminaire.
Ensure input voltage conforms to the voltage range of product.
Ensure wires are securely connected.
Before switching on, ensure that all the wiring is correct.
The warranty is void if product is not installed according to the instructions.