



HANECO
SIGNATURE

Discover the Future of Specialised Lighting Solutions

Advanced Optics & Engineering
Maximising performance and sustainability

Smart, Powerful, and **Built to Last**



HANECO
SIGNATURE

Innovation. Performance. Excellence.

The **Haneco Signature** range delivers high-performance lighting solutions for large-scale infrastructure and industrial environments. With precision engineering and advanced optics, it offers a range of specialised lighting solutions built for efficiency, durability, and adaptability in demanding applications.

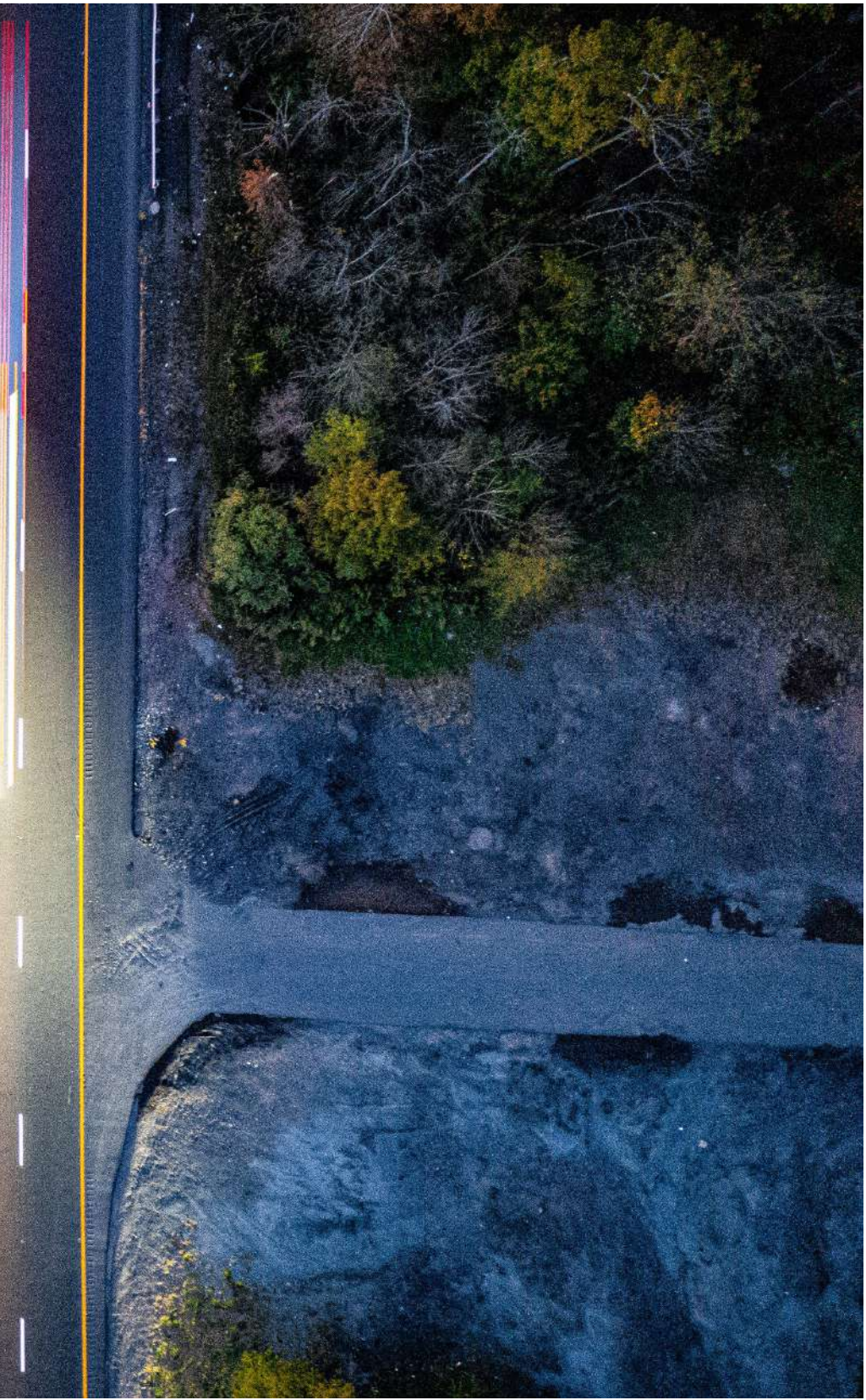

LUMINO

Streetlight



A contemporary and stylish, robust streetlight that uses advanced, energy-saving LED technology

LUMINO Streetlight, seamlessly combines advanced technology with efficiency to deliver optimal performance tailored to various project needs. Offering a range of options, the range is suitable for numerous applications including roadways, area lighting and carparks.

This luminaire is both versatile and reliable. LUMINO Streetlight features a robust die-cast aluminum construction ensuring durability, achieving an impressive 150 lumens per watt efficiency, offers flexible mounting options and the availability of an optional PE Cell accessory for enhanced functionality. The fixtures come standard with a 7-pin NEMA socket which ensure that it is smart-city ready.



Benefits

Smart city ready

- Supplied with 7-pin NEMA socket as standards
- 1-10V dimmable

Various options

- 8 output options; 4,500lms to 36,000lms (30W to 240W)
- 4000K

High reliability

- Independent 10KV surge protection
- Robust die-cast aluminum body
- High protection level IP66 & IK08

Adaptable Mounting

- Side and post top mountable for flexible applications
- Suitable for mounting on 40~60mm diameter
- Tilt angle adjustable

Applications

- Roadway and street lighting
- Carparks and area lighting
- Pathways and building surrounds

Dimensions

POWER (W)	L (mm)	W (mm)	H (mm)
30/60	467	175	88
80/120	564	221	88
150/180	642	241	88
200/240	740	276	88

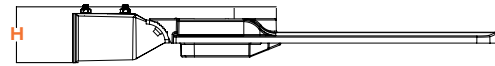
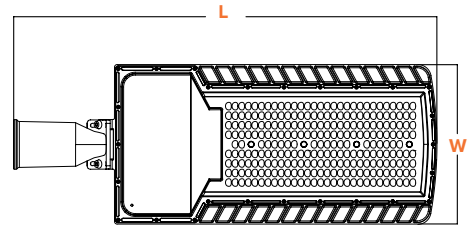

Specification

Body Material:	Die-cast Aluminum
Body Colour:	Black
Mounting Diameter:	Φ42mm and Φ60mm
Optical Construct:	PC (Polycarbonate)
IP Rating:	IP66
IK Rating:	IK08
Beam Angle:	Type 2
CRI:	> 80
SDCM:	≤ 5
Operating Temperature:	-20°C-40°C
Input:	AC120-277 50/60Hz
Surge Protection:	10KV
Total Harmonic Distortion:	<20%
Shorting Cap:	Yes
Power Factor:	>0.9
Lifespan:	50000 Hrs(Ta ≤ 25°C L70/B50)
Smart:	NEMA Connection
Warranty:	5 years

Photometrics

Light Distribution Curve

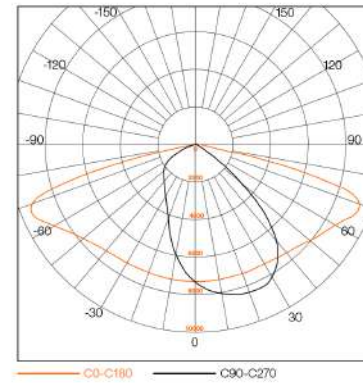

Due to the manufacturing processes of LED, the polar candela distribution and distance luminaries only reflect statistical figures and do not necessarily correspond to the actual parameters of individual product that may differ from the typical values.

Accessories

HS ST IP65 PE CELL FOR NEMA SOCKET

HSNEMAPE
4001266



HS ST VERTICAL WALL MOUNTING BRACKET BLACK - SPIGOT SIZE 40-60mm

HSWMBV4060
4001268



HS ST HORIZONTAL WALL MOUNTING BRACKET BLACK - SPIGOT SIZE 40-60mm

HSWMBH4060
4001267



HS ST SPIGOT ADAPTOR BLACK - SIZE 60 -76mm

HSSA6076
4001269



LUMINO^{PRO}

Streetlight



An innovative and durable street light, combining modern aesthetics with energy-efficient LED technology,

The LUMINO Pro Streetlight integrates cutting-edge technology and efficiency to deliver customised performance for a wide range of projects. Designed for illuminating area and streets, this luminaire offers adaptability and dependability. Key features include a choice between 3000K, 4000K or 5000K colour temperatures for desired ambiance, a robust die-cast aluminum build ensuring durability, an impressive efficiency of 150 lumens per watt, and a variety of optical options to meet diverse lighting requirements.



Benefits

Perfectly integrated into smart city control

- Smart city ready with 7-pin NEMA socket as standard
- 0-10V dimming as standard

Fulfill various application

- Power range from 60W to 240W
- CCT available from 3000K to 5000K
- Up to 150 lm/W efficacy
- Flicker free

High reliability

- Independent 10KV surge protection
- Robust aluminum body
- IP66 and IK08 rated

Applications

- General area lighting and street illumination
- City road and landscape lighting
- Pathways and parking lot
- Commercial district road lighting
- Industrial areas road lighting

Dimensions

POWER (W)	L (mm)	W (mm)	H (mm)
60	562	200	142
90/120	607	240	142
150/180	680	260	142
200/240	766	300	142

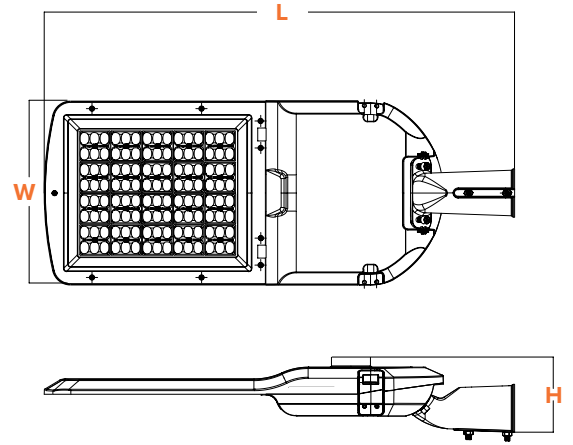

Specification

Body Material:	Di-cast Aluminum
Body Colour:	Silver
Mounting Diameter:	Φ60mm
IP Rating:	IP66
IK Rating:	IK08
Beam Angle:	Type 3, Type 4
CRI:	>70
Operating Temperature:	-25°C to 40°C
Input:	AC220-240
Surge Protection:	10KV
Shorting Cap:	Yes
Dimming	0-10v Dimmable, DALI (optional)
Lifespan:	54000h
Smart:	NEMA Connection
Warranty:	7 years

Photometrics

Light Distribution Curve

TYPE 3

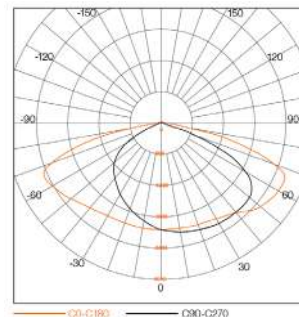

TYPE 4

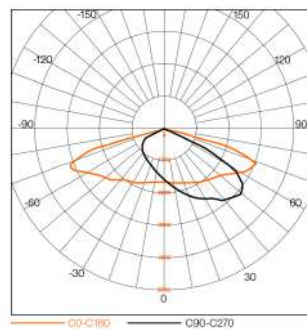

Due to the manufacturing processes of LED, the polar candela distribution and distance luminaries only reflect statistical figures and do not necessarily correspond to the actual parameters of individual product that may differ from the typical values.

Accessories

HS ST IP65 PE CELL FOR NEMA SOCKET

HSNEMAPE
4001266



HS ST VERTICAL WALL MOUNTING BRACKET BLACK - SPIGOT SIZE 40-60mm

HSWMBV4060
4001268



HS ST HORIZONTAL WALL MOUNTING BRACKET BLACK - SPIGOT SIZE 40-60mm

HSWMBH4060
4001267



HS ST SPIGOT ADAPTOR BLACK - SIZE 60-76mm

HSSA6076
4001269



SKYLUX-FG^{PRO}

FoodGrade Highbay



HACCP certified, energy-efficient food grade lighting that ideal for various industrial and commercial settings.

The SKYLUX FoodGrade PRO Highbay is a state-of-the-art lighting solution designed specifically for environments with stringent hygiene requirements. Its integrated die-cast aluminum shell offers robust protection with an IP65 rating, ensuring durability and optimal heat dissipation.

This lighting solution not only prioritises safety and comfort in industrial and commercial settings but also has full Australian HACCP accreditation. This certification guarantees compliance with the highest food safety and hygiene standards, making it an ideal choice for food processing and handling areas. With its smart design, dependability, and energy efficiency, the SKYLUX FoodGrade PRO Highbay is the perfect lighting solution for maintaining a safe and hygienic environment.



Benefits

High efficiency and durability

- Durable die-cast aluminum shell
- IP65 & IK08 rated
- Tri-wattage design for customised power usage
- Up to 160 lm/w efficacy
- Operating temperature: -25°C to 50°C

Efficient heat dissipation

- Advanced heat management technology and material for optimal heat dissipation
- Specialised cooling structure links radiator to heat source, extending lamp's lifespan

Various accessories available

- Accessories such as reflector and interchangeable lenses are available for customisation

Applications

- Food manufacturing and processing plants
- Commercial kitchen and food preparation areas
- Halls and indoor sports facilities
- Industrial warehouse

Dimensions

POWER (W)	Ø (mm)	H (mm)
60/80/100	300	127
120/140/160	345	138

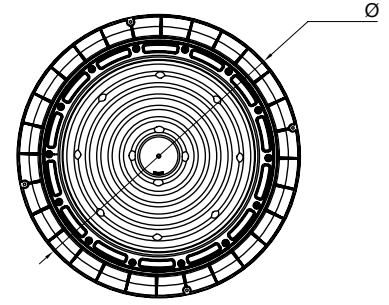
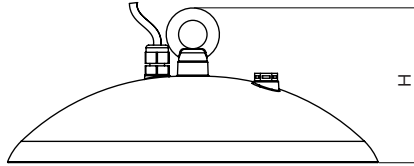

Specification

Body Material:	Die-cast Aluminum
Body Colour:	High Gloss White
Optical Construct	Polycarbonate
IP Rating:	IP65
IK Rating:	IK08
Beam Angle:	120°
CRI:	>80
SDCM	≤5
Operating Temperature:	-25°C to 50°C
Input:	AC120-277 50/60Hz
Surge Protection	6kV line-line, 6kV line-earth
Total Harmonic Distortion:	<20%
Power Factor:	>0.95
Lifespan:	54,000hr (Ta=50°C L80)
Smart:	Built-in daylight/microwave sensor (accessories)
Warranty	5 years
Mounting Type:	Suspending, bracket installation

Photometrics

Light Distribution Curve

60°

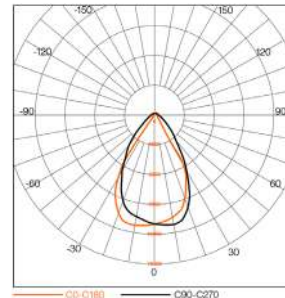

120°

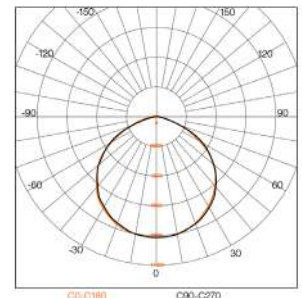

Due to the manufacturing processes of LED, the polar candela distribution and distance luminaries only reflect statistical figures and do not necessarily correspond to the actual parameters of individual product that may differ from the typical values.

Accessories

SKYLUX FOODGRADE PRO HIGHBAY SENSOR REMOTE

For easy sensor programming

SLFGPSENRT
4001279



SKYLUX FOODGRADE PRO HIGHBAY PC REFLECTOR - UNIVERSAL

SLFGPCRL
4001280



SKYLUX FOODGRADE PRO HIGHBAY LENS

60° Φ300
SLFGPL60300
4001281

90° Φ300
SLFGPL90300
4001283

60° Φ345
SLFGPL60345
4001282

90° Φ345
SLFGPL90345
4001284



SKYLUX FOODGRADE PRO HIGHBAY SENSOR

SLFGPSENSOR
4001285



Discover the Future of Lighting & Electrical Solutions

